



7030

 8 Ω

B46

PROFESSIONAL SERIES

18" Bass Extended Driver High Sounding Performance

APPLICATIONS

This model is intended to be used in Sub-Bass systems when high sounding performance or full outdoor environmental withstanding is requested.

Its main purpose is use in the field of Studio Monitoring. Its large linear displacement volume together with the smooth response up to 1 kHz are ideal for this application.

Recommended acoustical load is in a reflex enclosure of 220 to 300L tuned from 32 to 36 Hz. Maximum recommended X-over freq. is 400 Hz

DESIGN CONCEPT

DEFLECTION CONTROLLED DIAPHRAGM optimized for dynamic damping. DEFLECTION CONTROLLED DIAPHRAGM technology consists in optimizing the shape and material of the diaphragm so that it works as a mechanical transmission line, to avoid breaking modes as well as mechanical threshold which destroy sound quality.

This leading edge technology offers substantial sonic advantages. Among them: sound coherency, fast transients, stable sound imaging, high sensitivity, wide frequency range and reduced directivity pattern.

VENTED COMPACT MAGNET SYSTEM. It has been carefully optimized to obtain maximum transducing efficiency while avoiding unlinear behavior such as coil inductance variation with position, flux modulation, harmonic distortion, rest position offset, air compression and off-axis voice-coil pushing.

Its design incorporates a T-shaped and vented pole piece and a flux stabilization ring. It also takes into consideration demagnetization at cold temperatures.

INTERCOOLER SYSTEM (patented). Entirely integrated into the loudspeaker itself, the INTERCOOLER SYSTEM extracts the heat produced by Joule effect in the voice-coil by the means of an air flow directed through the heatsink rims of the basket by the motion of the dust-cap and the spider.

The gain brought about by this technology is over 20 % of extra power, so for example, a 3" coil according to this design has the same power handling capacity as a classical 4" one.



FEATURES

Power handling capacity **750 W AES**
Reference efficiency (1W @ 1m) **97 dB SPL**
SPL max (continuous) **122 dB SPL**
Usable frequency range **30-1000 Hz**
Environmental withstanding **Outdoor+**

ARCHITECTURAL SPECIFICATIONS

NOMINAL DIAMETER : 460 mm.

FRAME : Aluminum alloy pressure die-cast basket with patented INTERCOOLER SYSTEM.

MAGNET SYSTEM : 4" highly energized, heat extracting design with vented pole piece and flux stabilizing ring.

VOICE COIL : High-temperature stabilized copper wire wound on high-strength glass polyimide former.

CONE ASSEMBLY : High-strength cellulose fiber cone impregnated and coated on both sides with damped resins, fitted with central carbon-fiber dome and double roll treated and damped fabric surround.

SPEAKER MASS : 10.90 kg

7030

18" Bass Extended Driver

7030

TYPICAL CHARACTERISTICS

Rated impedance	Z	8	Ω
Reference efficiency (1 W@1 m)	-	97	dB SPL
Usable frequency range ¹	-	30-1000	Hz
Power handling capacity ² (AES)	-	750	W
Max Sound Pressure Level ³	SPL _{max}	122	dB SPL
Min. impedance modulus	Z _{min}	7.0 @ 200Hz	Ω
Voice-coil inductance ⁴ @ 1 kHz	L _{e1k}	1.71	mH
@ 10 kHz	L _{e10k}	0.82	mH
Bl product	Bl	22.7	N/A
Moving mass	M _{ms}	0.180	Kg

THIELE-SMALL PARAMETERS : TYPICAL (QC LIMITS)

Resonance frequency ⁵	F _s	34 (±5)	Hz
DC resistance ⁶	R _e	5.5 (±0.5)	Ω
Mechanical quality factor	Q _{ms}	4.8	1
Electrical quality factor	Q _{es}	0.41	1
Total quality factor	Q _{ts}	0.38	1
Mechanical suspension compliance	C _{ms}	115	10 ⁻⁶ m/N
Effective piston area	S _d	0.128	m ²
Equivalent C _{as} air load	V _{as}	0.260	m ³
Max. linear excursion	X _{max}	8.0	mm
Linear displacement volume	V _d	1.024	10 ⁻³ m ³
Half-space efficiency		2.5	%
Unity load volume	V _{as} Q _{ts} ²	41.4	10 ⁻³ m ³

ABSOLUTE MAXIMUM RATINGS

Short term max. input voltage ⁷	V _{max}	160	V
Max. excursion before damage	X _{dam}	16	mm
Ambient operating temperature		-10 to +50	°C
Storage temperature ⁸		-20 to +70	°C
Environmental conditions ⁹		Outdoor+	

APPLICATION INFORMATION

Air volume occupied by the driver ¹⁰		6.9	10 ⁻³ m ³
Speaker net mass		10.9	Kg
Recommended reflex box	V _b /F _b	250 / 35	L / Hz
Electrical polarity	A positive voltage applied on the red terminal produces forward cone motion.		

PHYSICAL CHARACTERISTICS

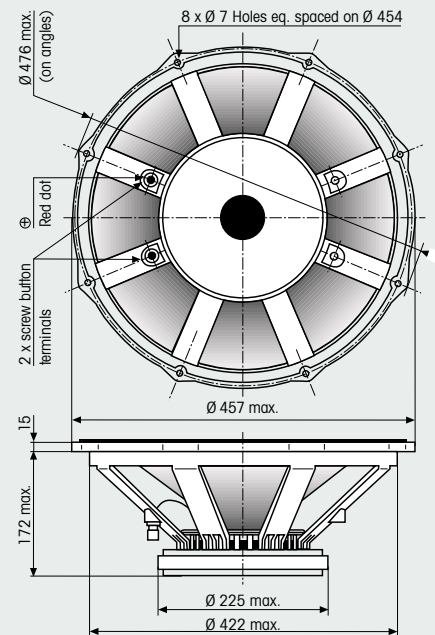

SPECIFICATION NOTES

- Note 1 : Allowing for energy response, excursion capability, Power spectrum, and -3dB low freq. roll-off for standard reflex tuning.
- Note 2 : Established at 20°C ambient temp, according to AES2-1984 standard using IEC268-1 simulated programme signal and a 150 liter Bass-Reflex test enclosure tuned at 40Hz.
- Note 3 : Established at 1m on axis of the loudspeaker mounted in test enclosure, when driven at full AES Power Handling Capacity, including 4dB of thermal compression loss.
- Note 4 : Measured at 20 mA in free air.
- Note 5 : Measured at 20 mA and 20°C ambient temp. in free air conditions, after full run and rest.
- Note 6 : Measured at 20°C ambient temp. QC limits are ±10%
- Note 7 : Stated in RMS voltage according to IEC 268-5.
- Note 8 : Includes shipping conditions. The lower limit prevents from demagnetization.
- Note 9 : Our products are classified in three categories : Indoor, Outdoor, and Outdoor+ for permanent outdoor use or severe conditions.
- Note 10 : Calculated for front mounting on to a 18 mm thick board.



461, rue des chênes.
Z.A.

77590 CHARTRETTES
FRANCE

Tél : 33 01 64 81 29 80

Fax : 33 01 60 69 10 28

e-mail : phlaudio@phlaudio.com