

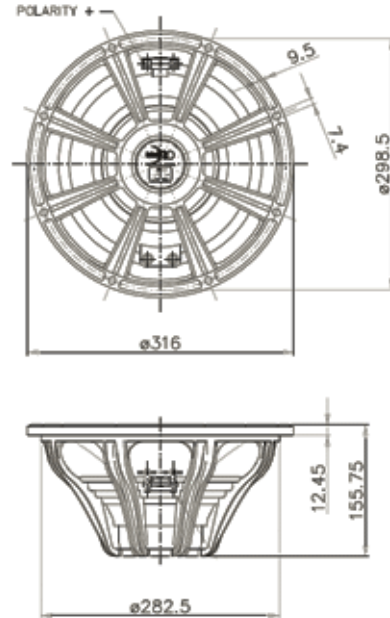

12FH500 Five Hundred Series



NOMINAL SPECIFICATIONS

Nominal Diameter	300 mm (12 in)
Overall Diameter	316 mm (12.44 in)
Bolt Circle Diameter	298.5 mm (11.75 in)
Baffle Cutout Diameter	284 mm (11.18 in)
Depth	155.75 mm (6.13 in)
Flange and Gasket Thickness	12.45 mm (0.49 in)
Net Weight	4 Kg (8.8 lb)
Shipping Box (Single Carton Box)	350x350x200 mm (13.8x13.8x7.9 in)
Shipping Weight	4.6 Kg (10.1 lb)

ELECTRICAL SPECIFICATION

Nominal Impedance	8 Ohm
Minimum Impedance	6.4 Ohm
Nominal Power Handling *	500 W
Maximum Power Handling **	1000 W
Sensitivity (1W/1m)	97 dB
Frequency Range	45÷4000 Hz
Voice Coil Diameter	77 mm (3 in)
Winding Material	Al
Former Material	Glass Fiber
Winding Depth	18 mm (0.71 in)
Magnetic Gap Depth	10.5 mm (0.41 in)
Flux Density	1.2 T

THIELE & SMALL PARAMETERS

Fs	45 Hz
Re	5.1 Ohm
Qes	0.26
Qms	6.90
Qts	0.25
Vas	76.2 dm ³ (2.69 ft ³)
Sd	490.4 cm ² (76 in ²)
Xmax ***	7.25 mm
Xdamage ****	16 mm
Mms	56 g
Bl	17.5 N/A
Le	0.83 mH
Mmd	50 g
Cms	0.22 mm/N
Rms	3.24 Kg/s
Eta Zero	2.5 %
EBP	173 Hz

NOTES

PATENTED IT2006/000327

(*) 2 Hours Test According to AES 2-1984 Rev. 2003

(**) Maximum power is defined as 3dB greater than nominal power.

(***) Xmax = [(winding depth - magnetic gap depth) / 2] + (magnetic gap depth / 3)

(****) Maximum excursion before permanent damage

CURVES

