



3FE22

3" - 20 W - 91 dB

NOMINAL SPECIFICATIONS

Nominal Diameter	80 mm (3 in)
Overall Diameter	105.6/81 mm (4.16/3.19 in)
Bolt Circle Diameter	92 mm (3.62 in)
Baffle Cutout Diameter	73.6 mm (2.90 in)
Depth	46 mm (1.81 in)
Flange and gasket Thickness	6.5 mm (0.26 in)
Net Weight	240 g (0.5 lb)
Shipping Box	285 x 285 x 255 mm
(Single Carton Box - 36 units)	(11.2 x 11.2 x 10.0 in)
Shipping Weight (36 units)	10 kg (22.0 lb)

TECHNICAL PARAMETERS

Nominal Impedance	16 Ω
Minimum Impedance	13.5 Ω
AES Power Handling (1)	20 W
Maximum Power Handling (4)	40 W
Sensitivity (1W/1m)	91 dB
Frequency Range	100 ÷ 20000 Hz
Voice Coil Diameter	19 mm (0.75 in)
Winding Material	Al
Former Material	Kapton
Winding Depth	5 mm (0.20 in)
Magnetic Gap Depth	4 mm (0.16 in)
Flux Density	1.4 T
Magnet	Neodymium Ring
Basket Material	Steel
Demodulation	No
Cone Surround (5)	Half Roll
NET Air Volume filled by Loudspeaker	0.060 dm ³ (0.002 ft ³)
Spider Profile	1x constant height waves

THIELE & SMALL PARAMETERS

Fs	110 Hz
Re	12.3 Ω
Qes	0.64
Qms	4.6
Qts	0.56
Vas	1.19 dm ³ (0.04 ft ³)
Sd	30.2 cm ² (4.68 in ²)
Xmax (2)	1.83 mm
Xdamage (3)	7.3 mm
Mms	2.3 g
Bl	5.5 N/A
Le	0.1 mH
Mmd	2.2 g
Cms	0.92 mm/N
Rms	0.34 kg/s
η _e (Eta Zero)	0.24 %
EBP	172 Hz

NOTE:

- 2 Hours Test According to AES 2-1984 Rev. 2003
 - Xmax = [(Winding Depth - magnetic gap depth)/2] + (magnetic gap depth / 3)
 - Maximum excursion before permanent damage
 - Maximum power is defined as 3dB greater than nominal power
 - NBR
- Packaged and sold in multiples of 36 units

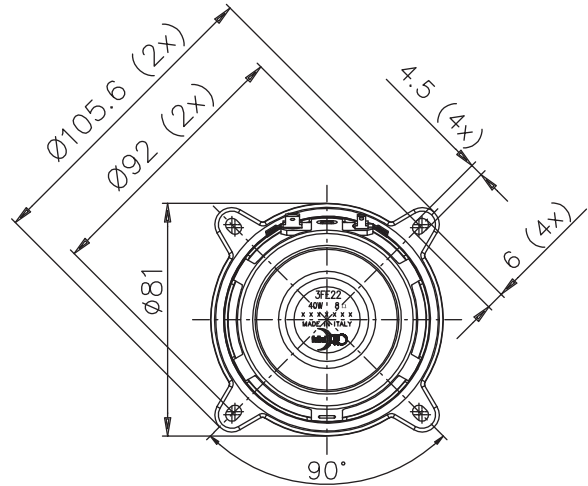

POLARITY +

