

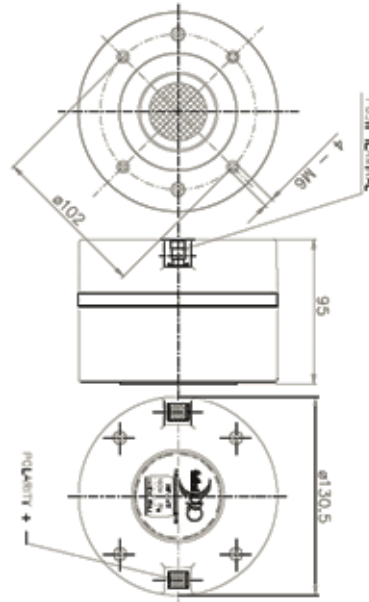

HF20AT Compression Driver



NOMINAL SPECIFICATIONS

Throat Diameter	50.8 mm (2 in)
Overall Diameter	130.5 mm (5.14 in)
90° Mounting Holes Diameter (4xM6)	102 mm (4.02 in)
Depth	95 mm (3.74 in)
Net Weight	3.3 Kg (7.28 lb)
Shipping Box	185x170x122 mm (7.28x6.69x4.80 in)
Shipping Weight	3.5 Kg (7.72 lb)

TECHNICAL PARAMETERS

Nominal Impedance	8 ohm
Minimum Impedance	7.2 ohm
Nominal Power Handling *	90 W
Maximum Power Handling **	180 W
Minimum Crossover Frequency ***	0.9 kHz
Sensitivity (1W/1m) ****	109 dB
Frequency Range	0.5÷18 kHz
Voice Coil Diameter	75 mm (2.95 in)
Winding Material	Copper Clad Aluminium
Former Material	Kapton
Diaphragm Material	Titanium
Winding Depth	2.45 mm (0.10 in)
Magnetic Gap Depth	2.80 mm (0.11 in)
Flux Density	2 T
Re	5.6 ohm
Phase Plug Design	Annular

NOTES

Driver mounted on a 2" 90° x 40° horn

(*) Test made for 2 hours with Pink Noise signal (6 dB Crest Factor) from minimum crossover frequency. Power calculated on rated minimum impedance. Driver mounted on aluminium horn.

(**) Maximum power is defined as 3dB greater than nominal power.

(***) 12 dB/oct or higher slope high-pass filter

(****) Averaged within the frequency range

CURVES

