



## KEY FEATURES:

- 100 db SPL 1W / 1m ( LF ) average sensitivity**
- 77 mm ( 3" ) high temperature voice coil ( LF )**
- 900 W AES program power ( LF )**
- Triple aluminium demodulating rings**
- Single magnet assembly**
- Double silicon spider**
- Water protected cone**
- 1.4" exit HF compression driver**
- 72 mm (2.85") HF high temperature voice coil**
- 80 degrees nominal dispersion**

**Application:** Stage monitors and compact bass reflex boxes.

**Description:** The 15CX is a 15" / 1.4" coaxial transducer designed for use in compact reflex enclosures and stage monitors with a nominal dispersion of 80 degrees. The low profile, smooth curvilinear LF cone provides smooth response within its intended frequency range and water prove protective coating, allowing application in a wide range of environments. The state-of-the-art 77 mm (3 in) LF voice coil has Kapton former, which together with high temperature resistant resin ensure high reliability by high power. A triple aluminium demodulating rings on the magnet structure reduce distortion and inductance and improve transient response. The 1.4" exit compression driver adopted is our D3672 model. The HF driver diaphragm assembly, using double layer polyester dome this together with phasing plug improve linearity of frequency response in high end. The HF magnet structure has cooper ring on the pole piece, which reduces the inductance figure of frequencies above 10 kHz, improving phase and impedance linearisation. This ensures extremely high SPL in the high end of the frequency response.

## SPECIFICATIONS

Nominal diameter	388 mm (15 in)
Impedance	LF 8 Ohm /HF 16 Ohm
Minimum impedance LF	6.20 Ohm
Frequency range	50 - 16000 Hz
Dispersion angle	80 deg

### LF unit

Sensitivity (200-2000 Hz)	100 dB
Power Capacity AES <sup>1</sup>	450 W
Program Power <sup>2</sup>	900 W
Voice Coil Diameter	77 mm (3 in)
Voice Coil Material	Copper
Voice Coil Former	Kapton
Voice Coil Winding Depth	18.5 mm
Magnet Gap Depth	9 mm.
Cone Material	Paper with glassfiber
Basket	Die Cast Aluminium
Magnet	Ferrite
Flux Density	1.15 T

### HF unit

Minimum impedance HF	11.59 Ohms
DC resistance	10 Ohms
Sensitivity (1000-15000 Hz)	106 dB
Power capacity (1000-20000 Hz)	75 W
Program power	150 W
Voice coil diameter	72 mm (2.85 in)
Winding material	Aluminium
Diaphragm material	sandwich polyester
Flux density	1.6 T

## THIELE-SMALL PARAMETERS

Resonance Frequency	38.2 Hz
Mechanical Efficiency Factor (Qms)	5.61
Electrical Efficiency Factor (Qes)	0.372
Total Q (Qts)	0.349
Equivalent Air Volume (Vas )	163.80 L
Diaphragm mass ind. airload (Mms)	101.84 g
Voice Coil Resistance Re	5.18 Ohms
Effective Diagram Area (Sd)	829 cm <sup>2</sup>
Peak Linear Displacement of Diaphragm (Xmax)*	± 7 mm
Mechanical Compliance of Suspension (Cms)	0.170 mm/N
BL Product (BL)	18.45 T.m
V.C. Inductance at 1 kHz (Le)	0.69 mH

## MOUNTING INFORMATION

Overall diameter	388 mm (15 in)
Depth	212 mm
Baffle hole diameter	352 mm
Bolt circle diameter	370/372 mm
Number of mounting holes	8 elliptic 7x8 mm
Net weight	10.90 kg

1. AES standard. Power is calculated on rated minimum impedance. Measurement is in 120 L box enclosure tuned 56 Hz using a 40-400 Hz band limited pink noise test signal applied continuously for 2 hours.

2. Program power is defined as 3db greater than AES Power Capacity.

\* Linear Mathematical Xmax is calculated as:  $(Hvc - Hg)/2 + Hg/4$  where Hvc is the voice coil depth and Hg is the gap depth.

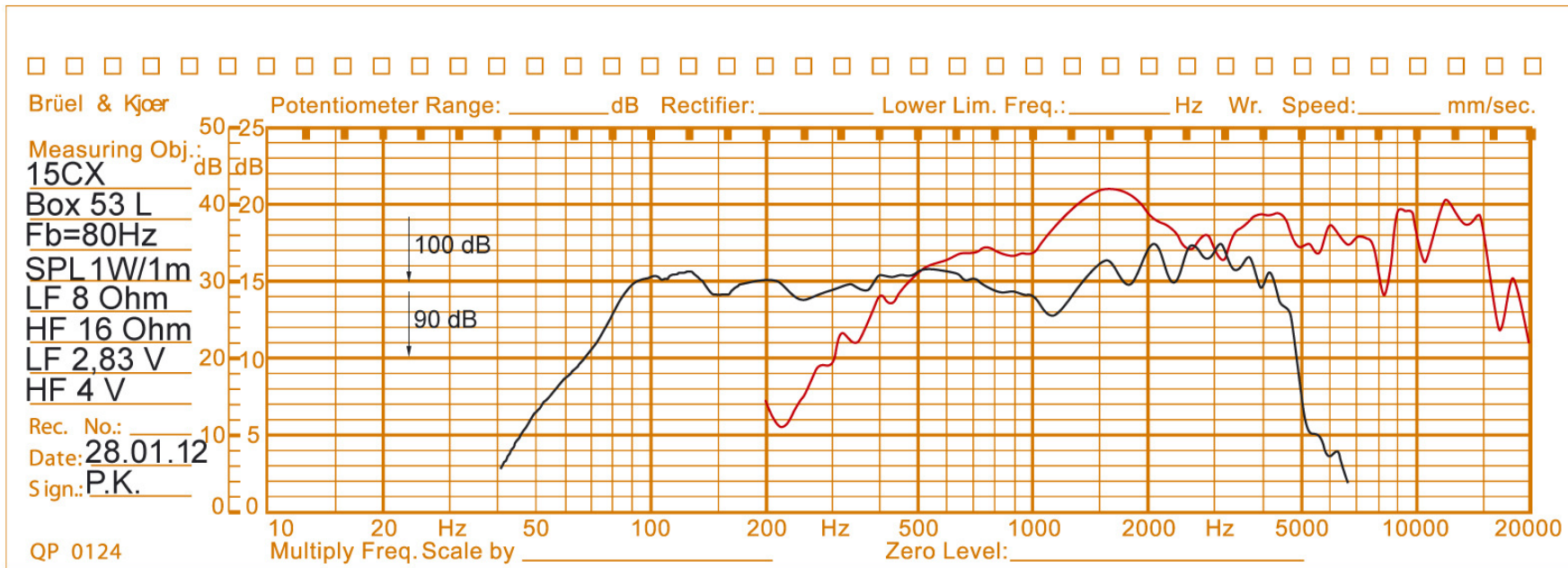

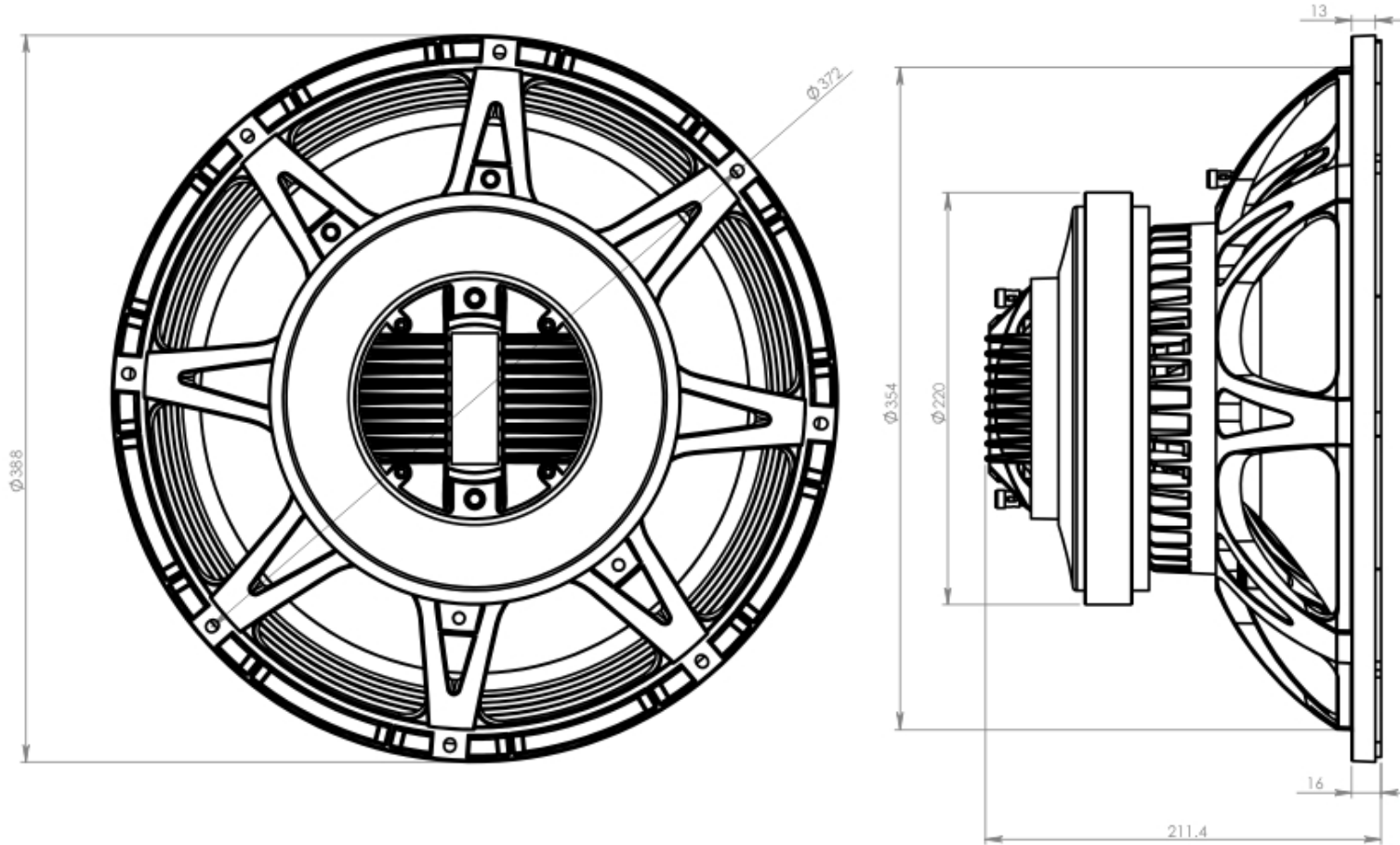

**OBERTON**

model: 15CX

Dimensions are in mm

Scale: 1:3