



KEY FEATURES:

98 db 1W / 1m average sensitivity

77 mm high temperature sandwich voice coil

1000 W AES program power

Powerful, vented 180 mm magnet structure

Aluminium demodulating ring for lower distortion and improved heat dissipation

Silicone spider

Application : Power bass

The 18B450 has been specially designed for low frequency reproduction in bass reflex enclosures. It features a vented die cast aluminium frame, 180 mm magnet structure and 3" voice coil. It is suitable for economic subwoofer application.

SPECIFICATIONS

Nominal Diameter	18"/461 inch/mm
Impedance	8 Ohm
Minimum Impedance	6.40 Ohm
Power Capacity AES ¹	500 W
Program Power ²	1000 W
Sensitivity	(50 - 200 Hz) 98 dB/W/m
Frequency Range	35 – 1000 Hz
Voice Coil Diameter	77 mm
Voice Coil Material	Copper
Voice Coil Former	Glassfiber
Voice Coil Winding Depth	20 mm
Magnet Gap Depth	11 mm
Cone Material	Paper
Basket	Die cast aluminium
Magnet	Ferrite
Flux Density	1.2 T

1. AES standard. Power is calculated on rated minimum impedance. Measurement is in 180 L box enclosure tuned 43 Hz using a 40-400 Hz band limited pink noise test signal applied continuously for 2 hours.

2. Program power is defined as 3db greater than AES Power Capacity.

* Linear Mathematical Xmax is calculated as: $(H_{vc} - H_g)/2 + H_g/4$ where H_{vc} is the voice coil depth and H_g is the gap depth.

THIELE-SMALL PARAMETERS

Resonance Frequency	34.38 Hz
Mechanical Efficiency Factor (Qms)	8.03
Electrical Efficiency Factor (Qes)	0.357
Total Q (Qts)	0.342
Equivalent Air Volume (Vas)	241.55 Litres
Diaphragm mass ind. airload (Mms)	152.76 grams
Voice Coil Resistance Re	5.29 Ohms
Effective Diagram Area (Sd)	1110 cm ²
Peak Linear Displacement of Diaphragm (Xmax)*	± 7.25 mm
Mechanical Compliance of Suspension (Cms)	0.140 mm/N
BL Product (BL)	22.12 T.m
V.C. Inductance at 1 kHz (Le)	1.49 mH

MOUNTING INFORMATION

Overall Diameter	461 mm
Baffle Hole Diameter	416 mm
Number of Mounting Holes	8 elliptic 7 x 8,5 mm
Bolt Circle Diameter	438/441 mm
Overall Depth	192.5 mm
Net Weight	8.55 kg

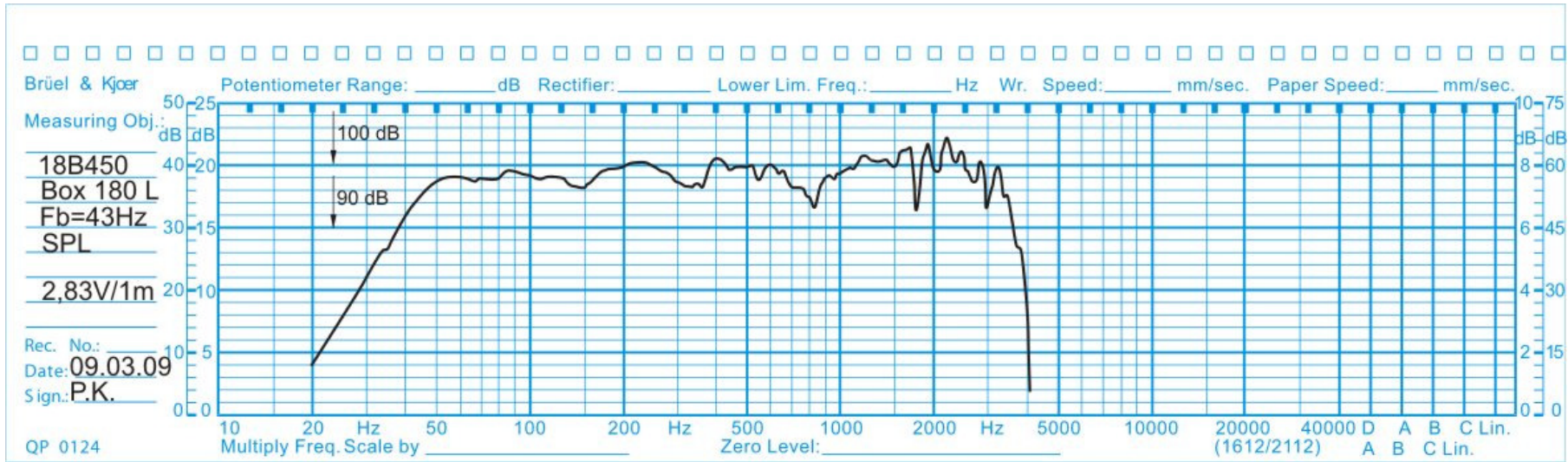

Frequency Response

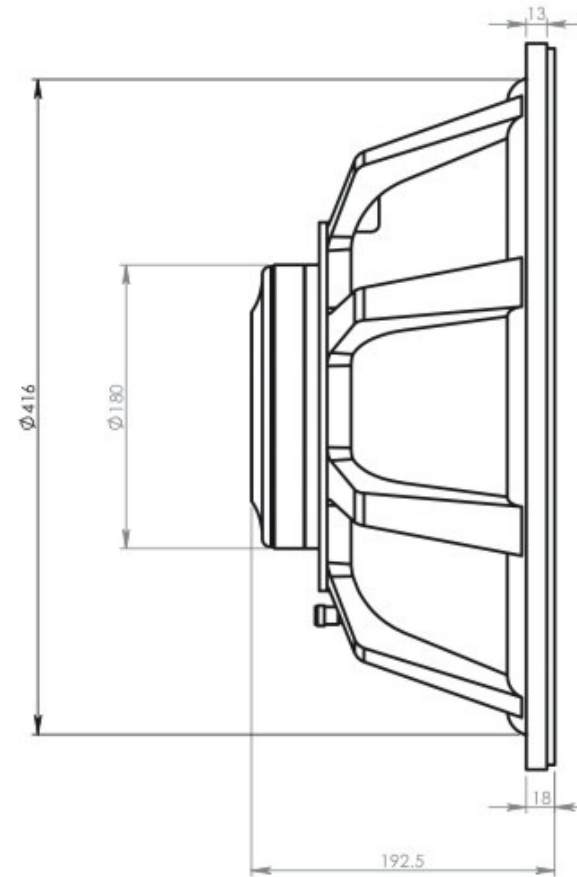
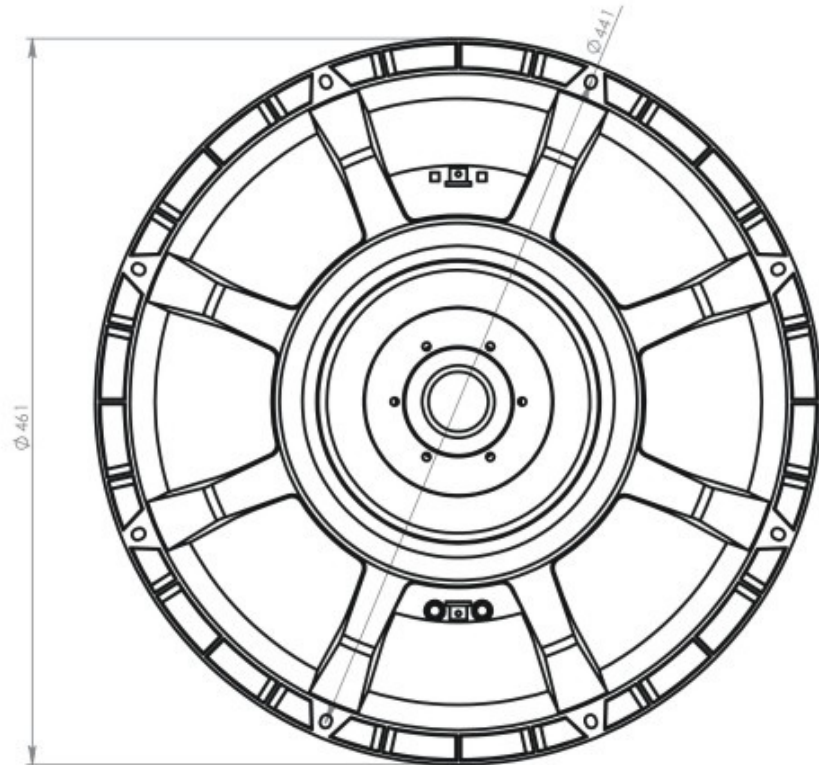

OBERTON	
model:	18B450