



#### KEY FEATURES:

**99 db 1W / 1m average sensitivity**

**77 mm high temperature sandwich voice coil**

**1200 W AES program power**

**Powerful, vented 220 mm magnet structure**

**Silicone spider**

#### Application : Power bass

The **18B500** loudspeaker are intended for high level, high power low frequency reproduction in ported enclosures. It feature vented die cast frame, 220 mm magnet structure, 3 inch voice coil and double spider assembly. This results in an very high sensitivity bass transducer for high power subwoofer application.

## SPECIFICATIONS

Nominal Diameter	18"/461 inch/mm
Impedance	8 Ohm
Minimum Impedance	6.38 Ohm
Power Capacity AES <sup>1</sup>	600 W
Program Power <sup>2</sup>	1200 W
Sensitivity	(50 - 200 Hz) 99 dB/W/m
Frequency Range	35 - 1000 Hz
Voice Coil Diameter	77 mm
Voice Coil Material	Copper
Voice Coil Former	Glassfiber
Voice Coil Winding Depth	23 mm
Magnet Gap Depth	11 mm
Cone Material	Paper
Basket	Die cast aluminium
Magnet	Ferrite
Flux Density	1.27 T

1. AES standard. Power is calculated on rated minimum impedance. Measurement is in 180 L box enclosure tuned 43 Hz using a 40-400 Hz band limited pink noise test signal applied continuously for 2 hours.

2. Program power is defined as 3db greater than AES Power Capacity.

\* Linear Mathematical Xmax is calculated as:  $(H_{vc} - H_g)/2 + H_g/4$  where  $H_{vc}$  is the voice coil depth and  $H_g$  is the gap depth.

## THIELE-SMALL PARAMETERS

Resonance Frequency	34.90 Hz
Mechanical Efficiency Factor (Qms)	9.24
Electrical Efficiency Factor (Qes)	0.284
Total Q (Qts)	0.275
Equivalent Air Volume (Vas)	243.91 Litress
Diaphragm mass ind. airload (Mms)	146.79 grams
Voice Coil Resistance Re	5.10 Ohms
Effective Diagram Area (Sd)	1110 cm <sup>2</sup>
Peak Linear Displacement of Diaphragm (Xmax)*	± 8.75 mm
Mechanical Compliance of Suspension (Cms)	0.142 mm/N
BL Product (BL)	24.06 T.m
V.C. Inductance at 1 kHz (Le)	1.37 mH

## MOUNTING INFORMATION

Overall Diameter	461 mm
Baffle Hole Diameter	416 mm
Number of Mounting Holes	8 elliptic 7 x 8,5 mm
Bolt Circle Diameter	438/441 mm
Overall Depth	204 mm
Net Weight	12.30 kg

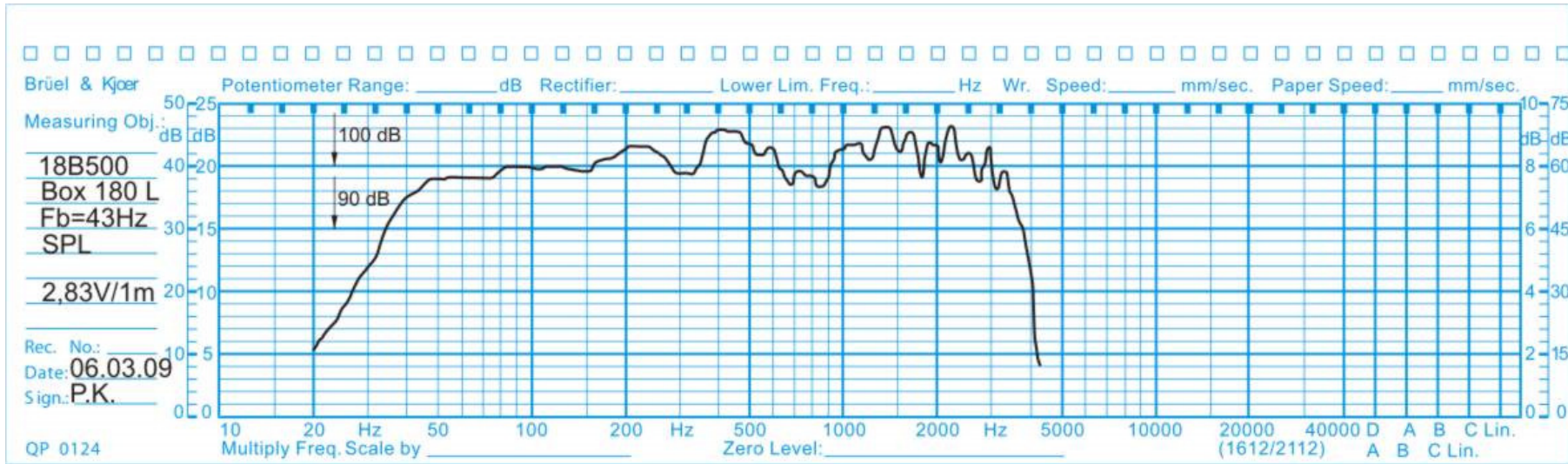

Frequency Response

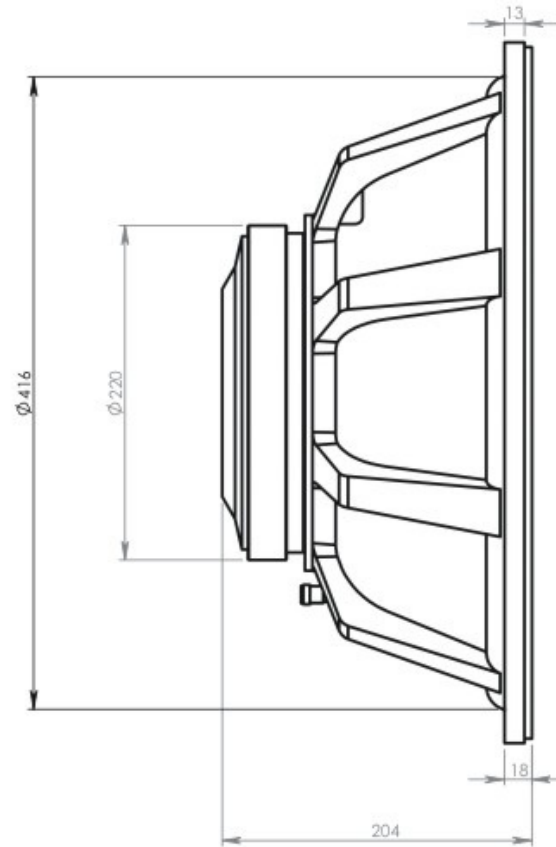
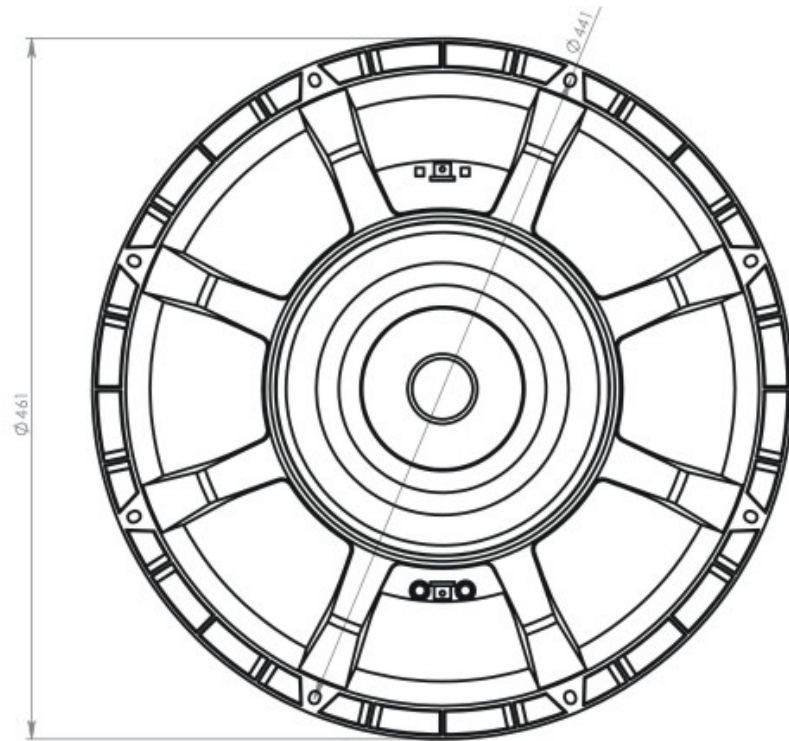

	OBERTON
model:	18B500