



1160

6.5 inches midrange driver

Nominal Diameter	6.5 " / 17 cm
Rated Impedance	8
Sensitivity	95.5 dB SPL
Power Handling Capacity	160 W AES
SPL max (continuous)	114 dB SPL
Usable frequency range	500 - 6000 Hz
Speaker net mass	2.15 kg



Architecture highlights :

- Midrange unit with critical damping diaphragm
- Natural convection Intercooler System

Motor architecture

Magnet material	-	Fe
Voice coil diameter	mm	38
Voice coil length	mm	7.5
Air gap height	mm	6

Typical characteristics

Rated impedance	Z	Ω	8
Half space sensitivity (1W@1m)	-	dB SPL	95.5
Usable freq. range	-	Hz	500 - 6000
Power handling capacity (AES)	-	W	160
Max Sound Pressure Level	SPL _{max}	dB SPL	114
Min. impedance modulus	Z _{min}	Ω@Hz	6.7@650
Voice-coil inductance @ 1kHz	Le _{1k}	mH	0.638
Voice-coil inductance @ 10kHz	Le _{10k}	mH	0.296
BL product	BL	N/A	10.3
Moving mass	Mms	kg	0.0098

Thiele-Small parameters

Resonance frequency	Fs	Hz	145 (±30)
DC Resistance	Re	Ω	6.1 (±0.6)
Mechanical quality factor	Qms	1	6.16
Electrical quality factor	Qes	1	0.51
Total quality factor	Qts	1	0.47
Suspension compliance	Cms	10 ⁻⁶ .m/N	120
Effective piston area	Sd	m ²	0.0150
Equivalent Cas air load	Vas	m ³	0.0039
Max linear excursion	Xmax	mm	± 2.0
Linear displacement volume	Vd	10 ⁻³ .m ³	0.0299
Reference efficiency	η ₀	%	2.2
Unity load volume	Vas.Qts ²	10 ⁻³ .m ³	0.9

Absolute maximum ratings

Short term max. input voltage	Vmax	V	70
Max. excursion before damage	Xdam	mm	± 4.0
Ambient operating temperature	Ta	°C	-10 to +50
Storage temperature		°C	-20 to +70
Environmental withstanding			Humidity proof

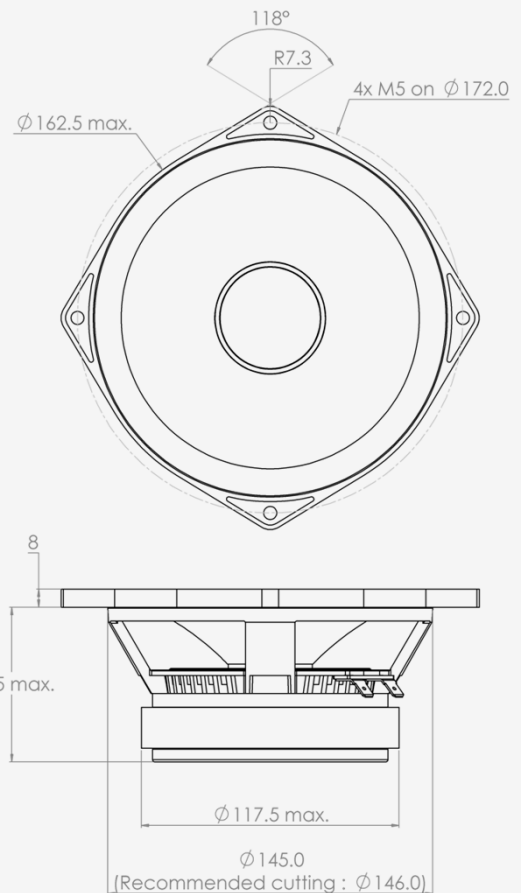

Mounting information

Air volume occupied by the driver	10 ⁻³ .m ³	0.46
Speaker net mass	kg	2.15
Baffle cut-out diameter (front mounting)	mm	146.0
Bolt number & Metric diameter	-	4x M5
Bolt circle diameter	mm	172.0
Max overall dimension (on ears)	mm	187.5
Max overall dimension (out of ears)	mm	162.5
Flange height	mm	8.0
Max magnet diameter	mm	117.5
Max depth (front mounting)	mm	68.5
Recommended reflex box	Lts / Hz	3L sealed
Electrical connection		6.35x0.8 FASTON