



1752NdU

Nominal Diameter	6.5 " / 17 cm
Rated Impedance	8
Sensitivity	95.5 dB SPL
Power Handling Capacity	200 W AES
SPL max (continuous)	116 dB SPL
Usable frequency range	100 - 4000 Hz
Speaker net mass	1.9 kg

6.5 inches low-mid driver



Architecture highlights :

- Neodymium magnet system with symmetric BL(x) and Le(x)
- Noiseless natural convection Intercooler System
- Ultra light CCAR voice coil

Motor architecture

Magnet material	-	Nd
Voice coil diameter	mm	51
Voice coil length	mm	11
Air gap height	mm	8

Typical characteristics

Rated impedance	Z	Ω	8
Half space sensitivity (1W@1m)	-	dB SPL	95.5
Usable freq. range	-	Hz	100 - 4000
Power handling capacity (AES)	-	W	200
Max Sound Pressure Level	SPL _{max}	dB SPL	116
Min. impedance modulus	Z _{min}	Ω @Hz	5.9@580
Voice-coil inductance @ 1kHz	Le _{1k}	mH	0.722
Voice-coil inductance @ 10kHz	Le _{10k}	mH	0.314
BL product	BL	N/A	11.9
Moving mass	Mms	kg	0.0122

Thiele-Small parameters

Resonance frequency	Fs	Hz	119 (± 20)
DC Resistance	Re	Ω	5.2 (± 0.5)
Mechanical quality factor	Qms	1	2.61
Electrical quality factor	Qes	1	0.33
Total quality factor	Qts	1	0.30
Suspension compliance	Cms	10^{-6} .m/N	150
Effective piston area	Sd	m ²	0.0145
Equivalent Cas air load	Vas	m ³	0.0044
Max linear excursion	Xmax	mm	± 3.0
Linear displacement volume	Vd	10^{-3} .m ³	0.0436
Reference efficiency	η_0	%	2.2
Unity load volume	Vas.Qts ²	10^{-3} .m ³	0.4

Absolute maximum ratings

Short term max. input voltage	Vmax	V	80
Max. excursion before damage	Xdam	mm	± 6.0
Ambient operating temperature	Ta	$^{\circ}$ C	-10 to +50
Storage temperature		$^{\circ}$ C	-20 to +70
Environmental withstanding			Humidity proof

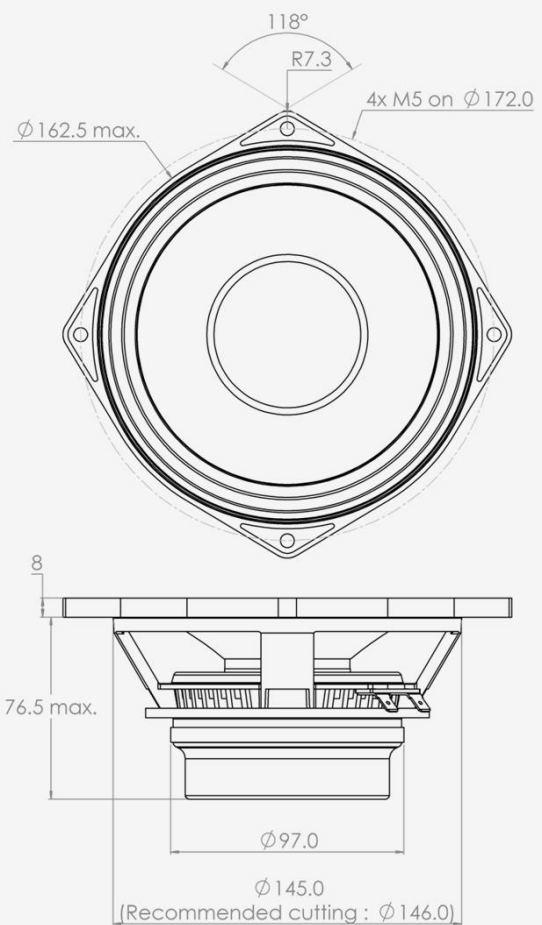

Mounting information

Air volume occupied by the driver	10^{-3} .m ³	0.50
Speaker net mass	kg	1.90
Baffle cut-out diameter (front mounting)	mm	146.0
Bolt number & Metric diameter	-	4x M5
Bolt circle diameter	mm	172.0
Max overall dimension (on ears)	mm	187.5
Max overall dimension (out of ears)	mm	163.0
Flange height	mm	8.0
Max magnet diameter	mm	98.0
Max depth (front mounting)	mm	76.5
Recommended reflex box	Lts / Hz	-
Electrical connection		6.35x0.8 FAS



1752NdU

6.5 inches low-mid driver

SPL curves measured on CEI standard baffle :

- . at 25 cm, normalised 1 m
- . at 1 m for reference
- . Graph amplitude = 60 dB (PHL Audio standard)

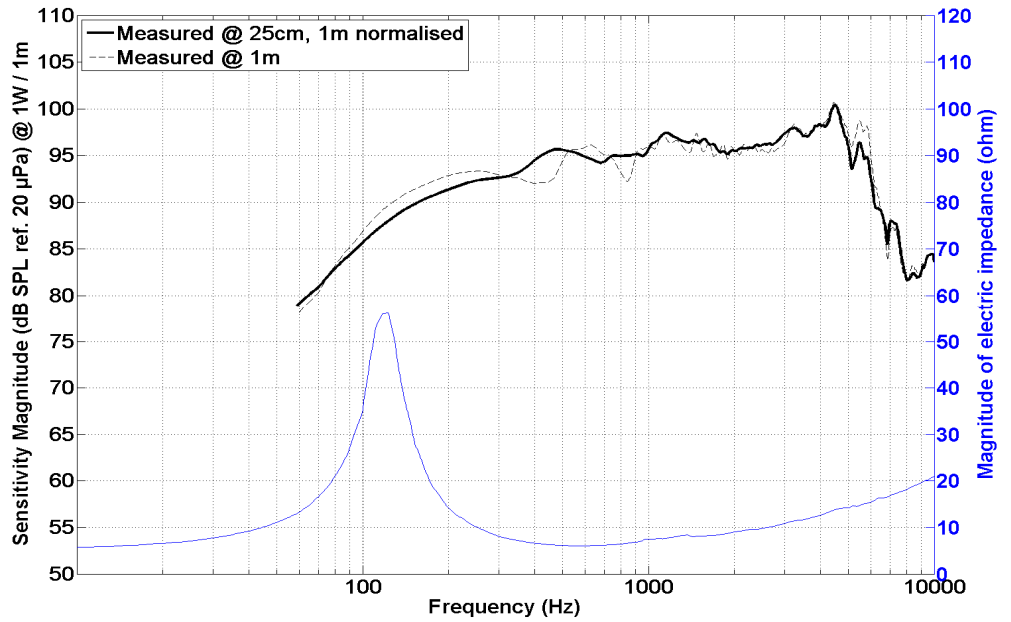

HD curve measured on CEI standard baffle :

- . at 1 meter
- . at power = $P_{AES} / 4$
- . Graph amplitude 0.01 % to 100 % (PHL Audio standard for $P_{AES}/4$)

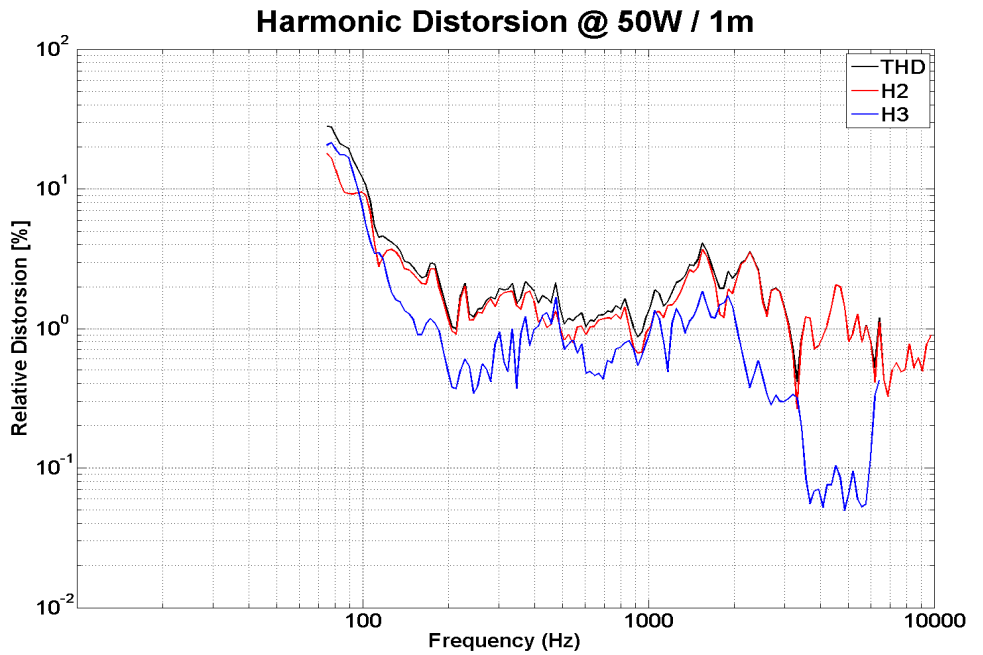

Non linear curves measured thanks to Klippel software and hardware, in free air

