

The Radian 5215B coaxial loudspeaker brings the best of 2" compression driver technology together with an excellent high performance 15" low frequency transducer. The 5215B utilizes a 4" voice coil for the low frequency transducer and a full 3" voice coil in the compression driver.

Radian's compression drivers utilize aluminum domes with an industry pioneering Mylar® surround that greatly reduces harmonic distortion at the same time improving reliability over one-piece metal diaphragms. The compression driver mates directly to a 2" horn throat machined into the center of the LF pole piece. The horn flare is completed by the cone of the woofer, resulting in excellent polar response at mid range frequencies and beyond.

This transducer system is capable of producing extremely high SPL, 127 dB continuous. This output is achieved over a bandwidth of 45 Hz to 20 kHz with 5 dB down points with 130 dB peak output levels.

Applications for the 5215B include demanding sound reinforcement main and monitor systems, and high ceiling convention center/ballroom installations where high SPL transducers are required.

The 5215B are normally equipped with an ohm woofer and 8 ohm compression driver. A 16 ohm compression driver impedance is available on order.



- ✓ **2" THROAT  
COMPRESSION DRIVER**
- ✓ **4" LF VOICE COIL**
- ✓ **15" LOW  
FREQUENCY SECTION**
- ✓ **90° CONICAL DISPERSION**
- ✓ **500 WATTS RMS**
- ✓ **CAST ALUMINUM FRAME**
- ✓ **HIGH SENSITIVITY**

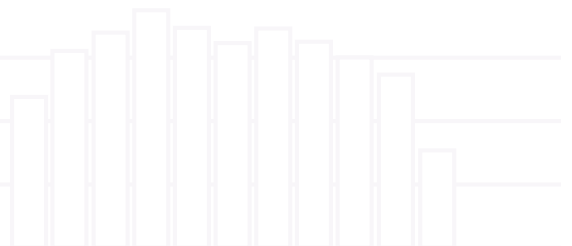

# 5215B



## 15" COAXIAL LOUDSPEAKER

### SPECIFICATIONS

FREQUENCY RESPONSE	45 Hz – 20 kHz
MAXIMUM POWER HANDLING*	500 watts RMS
SENSITIVITY**	97 dB
RECOMMENDED CROSSOVER	950 – 1250 Hz
NOMINAL IMPEDANCE	HF: 8 ohms, LF: 8 ohms
WOOFER DIAMETER	15.0" (381mm)
VOICE COIL DIAMETER (LF/HF)	4.0"/3.0" (101.6mm/76.2mm)
NOMINAL DISPERSION	90°
WOOFER CONE MATERIAL	Reinforced Paper
DIAPHRAGM MATERIAL	0.002" Aluminum
BASKET MATERIAL	Cast Aluminum
OVERALL DIAMETER	15.25" (387.35mm)
MOUNTING BOLT CIRCLE	14.56" (36.98mm)
CUT-OUT DIAMETER	14" (35.56mm)
OVERALL DEPTH	8.23" (209.04mm)
INPUT CONNECTORS:	
HF	0.25 Terminals (6.35mm)
LF	Pushbutton Terminals
WEIGHT	31 lbs. (14 kg)
THIELE/SMALL PARAMETERS:	
QTS	0.313
QMS	3.243
QES	0.346
VAS	6.8 (ft. <sup>3</sup> ), 192.4 (liter)
Fs (Hz)	39
XMAX (IN)	0.112"
RE (Ω)	5.9
SD (IN <sup>2</sup> )	137 (0.089M <sup>2</sup> )

\*EIA Standard RS-426A

\*\*One watt at one meter

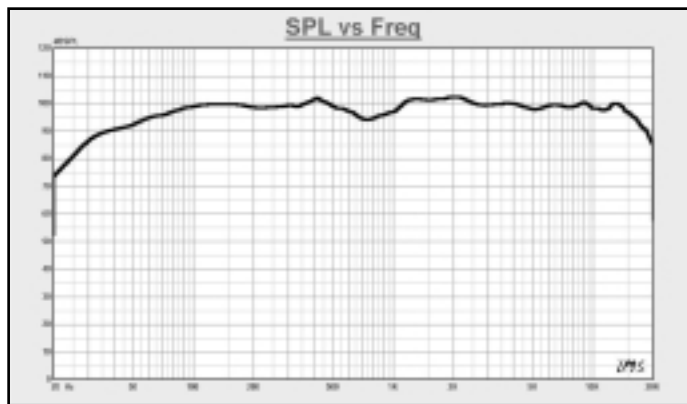

Amplitude vs. Frequency Response of the Radian 5215B as measured on axis with a one watt (2.83 Vrms), swept sine wave input at 8 ohms, using a 322/15 crossover network in a 3.4 (ft.<sup>3</sup>) vented cabinet.

Specifications subject to change without notice.

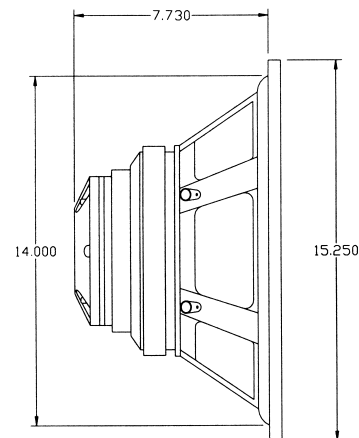

#### LIMITED WARRANTY

Radian Audio Engineering, Inc. products, when sold domestically, are guaranteed for a period of five (5) years from the date of original purchase against malfunctions due to defects in workmanship. If such a malfunction occurs, the product will be repaired or replaced at our option, without charge, if delivered prepaid to the factory. Product will be returned prepaid via ground transport. This warranty does not extend to damage resulting from improper installation, misuse, neglect or abuse. The warranty does not apply to external finish or appearance. The warranty does not apply to burnt voice coils. In no event shall Radian Audio Engineering, Inc. be liable for incidental or consequential damages including, without limitation, injury to persons or property or loss of use.

600 N. Batavia Street  
Orange, CA 92868  
Phone: (714) 288-8900  
Fax: (714) 288-1133  
E-mail: [radian@radianaudio.com](mailto:radian@radianaudio.com)  
Web: [www.radianaudio.com](http://www.radianaudio.com)