

# MID-BASS L10/750YK

Professional Low Frequency Transducer

The L10/750YK is a professional mid-bass woofer featuring very high output and dynamics. The mobile equipment, used a 3" coil, fibreglass former and copper wire winding, has enabled considerable improvement in transient peak response and has allowed good extension on mid-high frequencies. A specially designed M-roll surround guarantee a very low midrange distortion and perfect damping of the spurious resonances.

PART NUMBER 11130015

## Features

- 3-inch, fibreglass inside-outside copper voice coil
- 700 Watt continuous program power handling
- 100 dB Sensitivity
- 70 Hz - 3 kHz Frequency range
- Shaped M-roll damped surround

## Applications

The L10/750YK is primary designed to be horn loaded in medium and long throw systems. When mounted in compact size bass reflex enclosures, the good combination of short voice coil, very low mass and suspensions control makes the L10/750YK a very good choice for high power, 2 way, satellite applications.

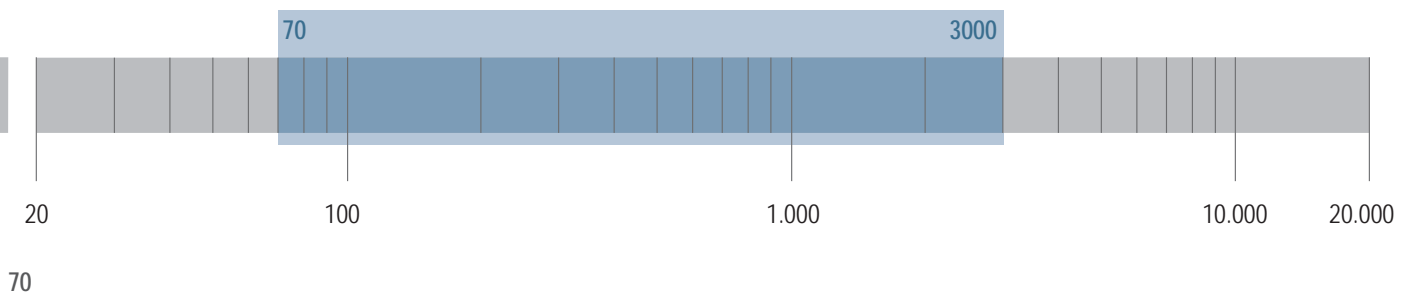

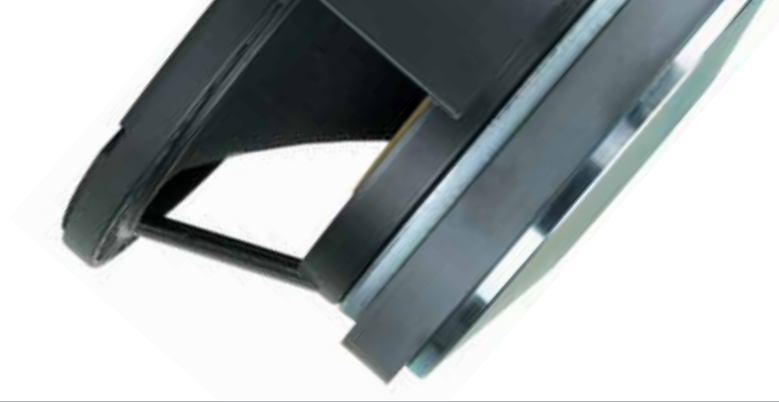

8 holes  $\phi$  7 mm to  $45^\circ$   
on  $\phi$  242 mm and on  $\phi$  247 mm

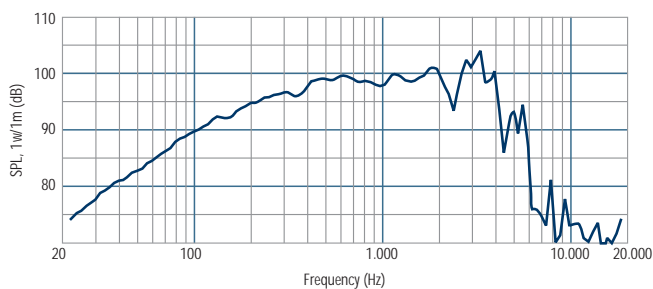
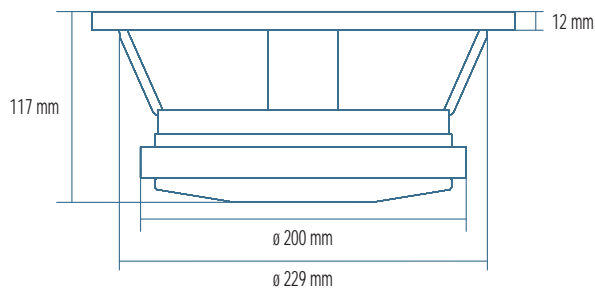
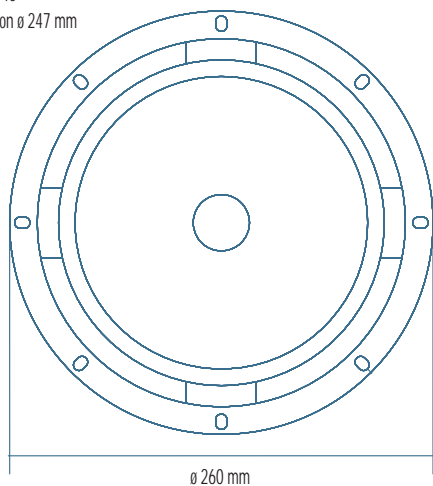

Frequency response curve of the loudspeaker taken in a hemispherical, free field environment and mounted in a closed box with an internal volume of 600 litres (21.2 cu.ft) enclosing the rear of the driver.

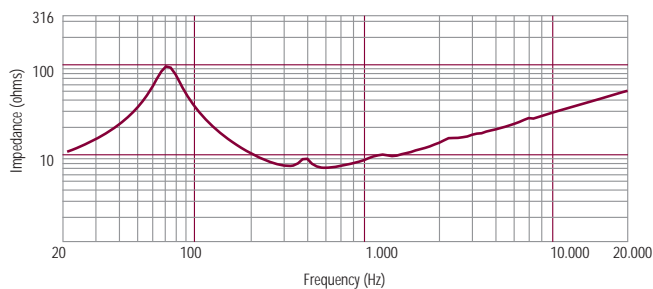

Impedance magnitude curve measured in free air.

## Notes to Specifications

1 Program Power is defined as 3 dB greater than AES power. - 2 AES standard. - 3 Sensitivity measurement is based on a 500-2 kHz pink noise signal with input power of 2.83V @ 8 Ohms. - 4 Thiele-Small parameters are measured after a 2 hour warm up period running the loudspeaker at full power handling capacity. - 5 The maximum linear excursion is calculated as:  $(Hvc - Hg)/2 + Hg/4$  where Hvc is the voice coil depth and Hg the gap depth. - 6 Calculated for front mounting on 18 mm thick board.

## General Specifications

Nominal Diameter	250/10	mm/inch
Rated Impedance	8	ohm
Program Power <sup>1</sup>	700	Watts
Power handling capacity <sup>2</sup>	350	Watts
Sensitivity <sup>3</sup>	100	dB
Frequency Range	70 - 3000	Hz
Effective Piston Diameter	210/8.3	mm/inch
Max Excursion Before Damage (peak to peak)	40/1.6	mm/inch
Minimum Impedance	6.7	ohm
Voice Coil Diameter	76/3	mm/inch
Voice Coil Material	Copper	
Voice Coil Winding Depth	9/0.35	mm/inch
Number of layers	2	
Kind of layer	inside/outside	
Top Plate Thickness	9/0.35	mm/inch
Cone Material	No pressed pulp	
Cone Design	Curved	
Surround Material	Polycotton	
Surround Design	M - roll	

## Thiele - Small Parameters <sup>4</sup>

Resonance frequency	Fs	68	Hz
DC resistance	Re	5.1	ohm
Mechanical factor	Qms	4.2	
Electrical factor	Qes	0.25	
Total factor	Qts	0.24	
BL Factor	BL	17.5	T · m
Effective Moving Mass	Mms	36	gr
Equivalent Cas air load	Vas	26	liters
Effettive piston area	Sd	0.035	m <sup>2</sup>
Max. linear excursion (mathematical) <sup>5</sup>	Xmax	2.5	mm
Voice - coil inductance @ 1KHz	Le1K	1.3	mH
Half-space efficiency	Eff	3.15	%

## Mounting Information

Overall Diameter	260/10.6	mm/inch
Bolt Circle Diameter	242-247/9.2-9.7	mm/inch
Bolt Hole Diameter	5.5/0.2	mm/inch
Front Mount Baffle Cut-out	230/9.1	mm/inch
Rear Mount Baffle Cut-out	229/9.0	mm/inch
Depth	120/4.7	mm/inch
Volume occupied by the driver <sup>6</sup>	1.2/0.04	liters/ft3

## Shipping Information

Net Weight	7.70/16.9	Kg/Lbs
Shipping Weight	8.10/17.8	Kg/Lbs