

6" - 200W Dual Cone Loudspeaker

6 D 1,5 SL - 4 Ω

Code Z004066

GENERAL CHARACTERISTICS		
Nominal Overall Diameter	165	mm
Nominal Voice Coil Diameter	38	mm
Magnet Weight	126	g
Flux Density.....	1.15	T
Weight.....	0.90	Kg

ELECTRICAL CHARACTERISTICS		
Nominal Impedance.....	4	Ω
Musical Power	200	W
Rated Power*	100	W
Sensitivity @ 1 W, 1 m	91.2	dB

THIELE-SMALL PARAMETERS		
Voice Coil DC Resistance	R_E	3.25 Ω
Resonance Frequency	f_s	84.8 Hz
Mechanical Q Factor.....	Q_{MS}	1.85
Electrical Q Factor.....	Q_{ES}	0.58
Total Q Factor	Q_{TS}	0.44
Mechanical Moving Mass	M_{MS}	11.6 g
Mechanical Compliance	C_{MS}	303 μm/N
Force Factor	$B \times l$	5.87 Wb/m
Equivalent Acoustic Volume.....	V_{AS}	6.5 lt.
Maximum Linear Displacement	X_{MAX}	+/-4.0 mm
Reference Efficiency	η_0	0.65 %
Diaphragm Area	S_D	122.7 cm ²
Losses Electrical Resistance.....	R_{ES}	10.3 Ω
Voice Coil Inductance @ 1kHz	L_E	0.18 mH

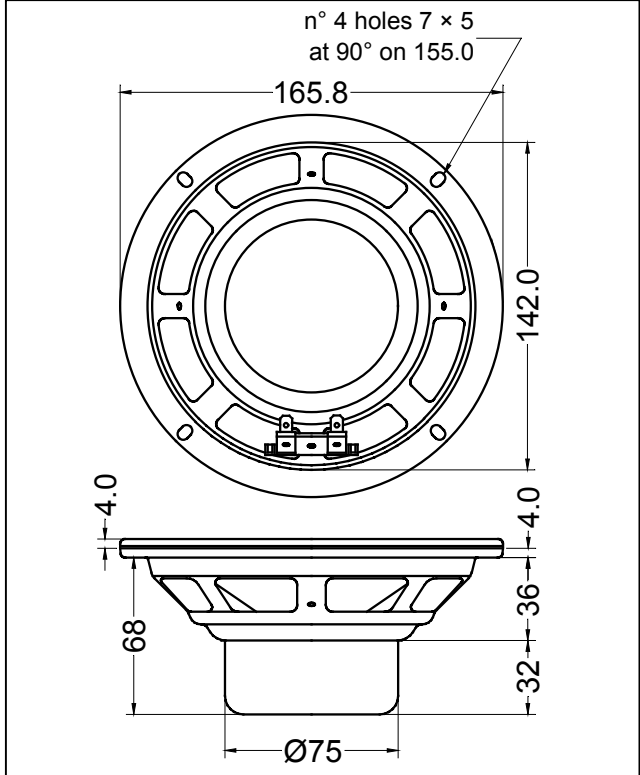

CONSTRUCTIVE CHARACTERISTICS	
Magnet.....	Neodymium
Voice Coil Winding.....	Aluminium
Voice Coil Former.....	Kapton
Cone	Paper
Surround.....	Treated Cloth
Dust Dome	Treated Cloth
Basket	Pressed Sheet Steel

**rated power measured with 2 hours test with pink noise signal, 6 dB crest factor, loudspeaker mounted on enclosure
Thiele-Small parameters measured with LASER system*

Frequency Response on IEC Baffle (DIN 45575) @ 1 W, 1 m - Impedance

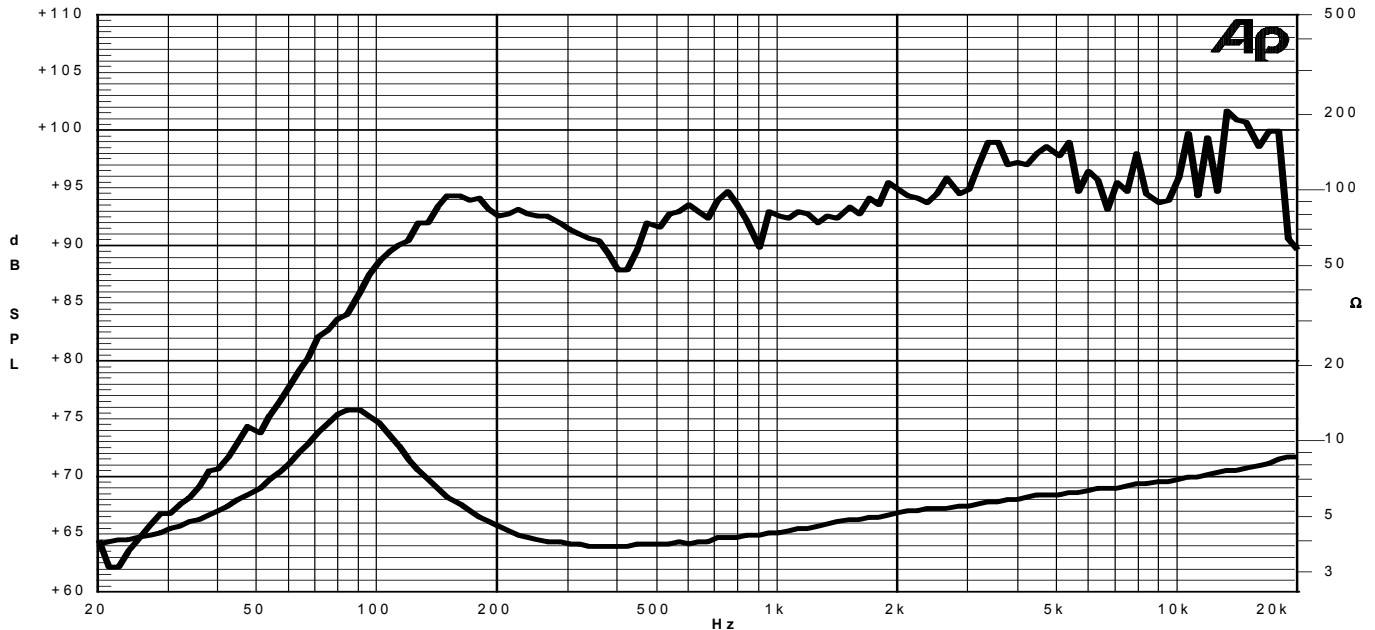

Due to continuing product improvement, the features and the design are subject to change without notice.

13/05/10